

Atlas Garage Pro 8000

8,000 lb. Capacity
Four-Post Hobbyist Lift



Atlas Automotive Equipment
www.atlasautoequipment.com
(866) 898-2604

Read this entire manual before operation begins.

Record below the following information which is located on the serial number data plate.

Serial No. _____

Model No. _____

Date of Installation _____

———— Contents ————

Important Information	4
Specifications	6
Tools Required For Installation	7
Installation Procedure	8
Foundation Requirements	13
Lift Lockout/Tagout Procedure	15
Important Safety Instructions	17
Operation Instructions.	20
Troubleshooting.	24
Cable Inspection Guide	27
Illustrated Parts Breakdown	32
GP8000 Parts List	38
Warranty	41

Important Information

1. Always inspect the lift for damage and make note of any damage on the bill of lading.
2. In case of freight damage, call the truck line immediately and report the damage as a freight claim.
3. Make sure you have extra help or heavy duty lifting equipment when unloading and assembling the lift.
4. Please read the safety procedures and operating instructions in this manual before operating lift. Keep this manual near lift at all times. Make sure all operators read this manual.
5. **NOTE: Are you installing in a level location? (Lift must be anchored in place if slope is greater than 1/8" per foot.)**
6. Make sure you have enough room to install the lock rods. **You will need at least 9' of clearance from the opposite end of the power unit end of the lift and 6' at the power unit end. (See floor plan on page 6).** The power unit may be installed on the driver's front or the passenger rear corner.
7. Never raise a car until you have double checked all bolts, nuts and hose fittings.
8. Always lower the lift to locks before going under the vehicle or storing another vehicle underneath lift. Never allow anyone to go under the lift when raising or lowering.

This is a vehicle lift installation/operation manual and no attempt is made or implied herein to instruct the user in lifting methods particular to an individual application. Rather, the contents of this manual are intended as a basis for operation and maintenance of the unit as it stands alone or as it is intended and anticipated to be used in conjunction with other equipment.

Proper application of the equipment described herein is limited to the parameters detailed in the specifications and the uses set forth in the descriptive passages. Any other proposed application of this equipment should be documented and submitted in writing to the factory for examination. The user assumes full

responsibility for any equipment damage, personal injury, or alteration of the equipment described in this manual or any subsequent damages.

Read this manual thoroughly before installing, operating, or maintaining this lift. When done with installation, be sure to return documents to package and give all materials to lift owner/operator. When installation is complete be sure to run lift up and down a few cycles with and without "typical" vehicle loaded on lift.

Specifications

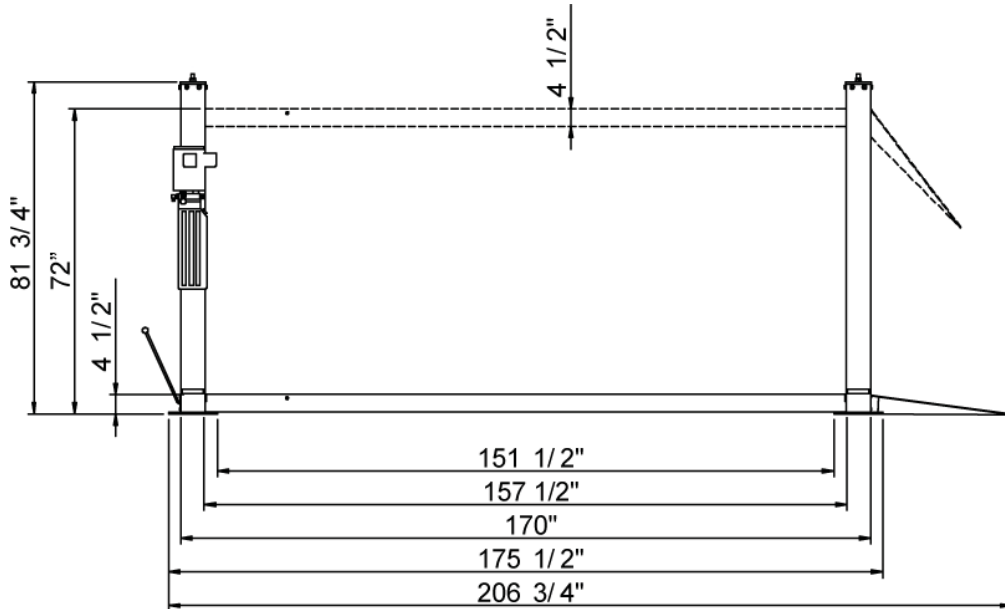

YOU WILL NEED A MIN. OF 6' CLEARANCE IN FRONT TO INSTALL HANDLE ROD

YOU WILL NEED A MIN. OF 9' CLEARANCE IN REAR TO INSTALL "T" ROD

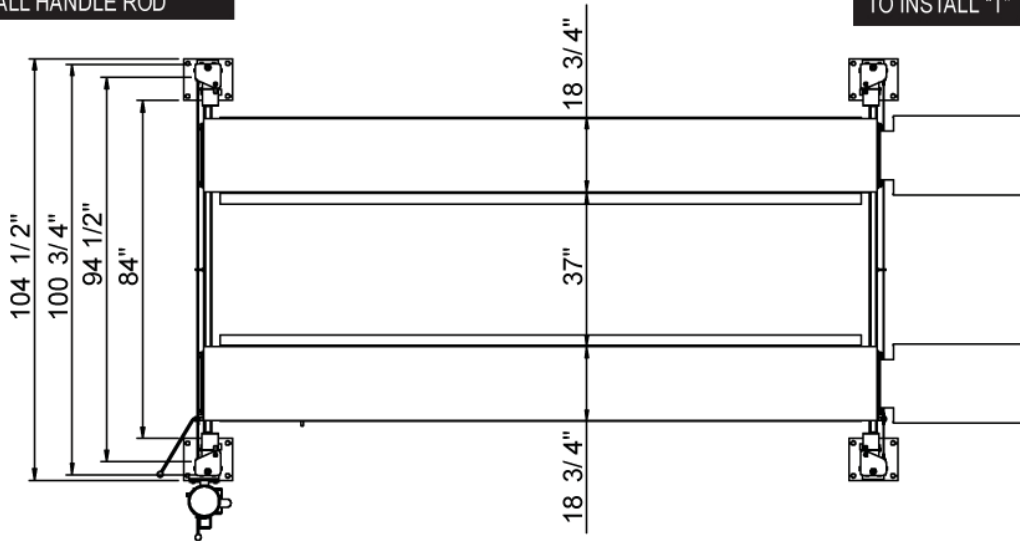

Technical Data

Lifting Height	72"
Overall Length with Ramps	206-3/4"
Overall Length without Ramps	175-1/2"
Overall Width	104-1/2"
Height Of Columns	81-3/4"
Runway Width	18-3/4"
Runway Height	4-1/2"
Clearance Between Runways	37"
Capacity	8000 lbs.

Tools Required For Installation

The installation of this lift is relatively simple and can be accomplished by two men in a few hours.

The following tools and equipment are needed:

- Set of metric wrenches and/or sockets
- Locking pliers
- Adjustable wrench
- 25' Tape measure
- ISO 32 Light Hydraulic Oil (approx. 3 gallons)
- Step Ladder

Installation Procedure

1. Remove plastic wrap from top runway and remove all hardware, safety lock rods, hoses and cables. You should also find this manual in the top runway.
2. Find the end of the hose that is already mounted to the cylinder and tighten the elbow that attaches the hose to the side of the runway using the jam nut. Also, check the fitting at the cylinder end and make sure it is tight.
3. Extend cylinder rod out of the cylinder to about 18" from end of runway. This can be done by pulling or pushing on the ½" plate on the end of the cylinder. Make sure that the ½" plate is threaded tight against the cylinder rod. Also, be sure the ¼" plate is on the rod and hand tighten the lock nut on the end of the cylinder.
4. Unbolt the top runway from the shipping plates at each end of the package. Be sure to secure runway with hoist to prevent runway from falling. Runway will need to be turned over so it is no longer upside down. Place this runway in your bay with the hydraulic fitting facing towards the outside (see Page 1).
5. Next, unbolt the four columns from the package and place the column with the power unit mounting bracket at the end of the previously unpacked runway nearest to the hydraulic fitting. Stand these columns on their base plates with the locking ladders facing to the outside (front to rear) and pulleys toward the inside (see Fig. 1 on page 32).
6. Unpack the bottom runway. Lay the approach ramps near the approach end of the lift and set out the remaining parts away from the lift. Place the two cross rails at each end of the lift with the locks toward the outside (front or rear) of the lift (see Fig. 1). Remove the shipping brackets from the bottom runway and turn over placing the runway in the bay next to the other runway with the "L" shaped side facing the "L" shaped side of the other runway.
7. If you have a means for securely lifting cross rails high enough to lower them into the top of the columns, then remove the top plates from the top of the columns while the columns are standing. If you don't have a means for securely lifting them, then you will need to lay the columns down and remove the top plates to allow the cross rails to be slid into the columns.
8. Slide each cross rail into the front or rear two columns by holding the lock lever down, to allow the rail to slide past the locking positions. Leave the

cross rail locked in the lowest position on the column. Repeat this step for the other cross rails (see Fig. 1).

9. Position the front cross rail columns at 170" from the rear cross rail columns by measuring from the outsides of the columns. Square the lift by measuring diagonally between the right, front column to the same position on the lift rear column. Compare your measurement between the left front column and the right rear column. This should be within ½" to allow some forgiveness to bolt on runways.
10. Lift the runways onto the cross rails and bolt them in place using the ¾" holes towards the outside of the cross rails. The four drop-in ramp plates will be used with the spacer side facing the lift and through-bolted from the outside of the cross rail, through the runway using bolts provided with washers. Lock washers and nuts (see Fig. 2).
11. After runways are bolted on, install the column top plates back to their original columns and tighten.

Cable Installation

12. Lay out all cables and measure from end to end to determine correct cable positions (see Fig. 3).
13. Since the nub end of the cable is easier to feed through the pulley, start with the pulley at the end of the cross bar and work your way back to the cylinder (see Fig. 3).
14. Install cable nubs into appropriate slots in ½" plate and secure with slots on ¼" plate. Tighten the nubs so the nylock nut is fully threaded onto the head of the cylinder. This cable bracket should still be able to move freely on the cylinder head.
15. Run the threaded cable ends into the hole in the top caps and secure with washer and nylock nut. Hand tighten only, final adjustment will be made later. Do tighten the nylock nut on the end of the cylinder at this time.

Hydraulic Assembly

16. Be sure wiring is in compliance with your local electrical codes.
17. Rind the four 5/16" bolts, nuts and lock washers and attach the power unit to the mounting bracket on the column.
18. Remove dust cover from the port on the side of the power unit and attach the "O" ring elbow. Do not over tighten. The backing nut and "O" ring will complete the seal to the power unit.
19. Install the 3/8" hose to the fitting on the side of the runway and connect opposite end to the fitting on the power unit. Tighten JIC fittings carefully, do not over tighten.

Lock Linkage Assembly

20. The single point safety lock is a system of connecting rods and linkage that disengage the four lock latches that secure the lift to each column.

Locate the six rods: 2 – long rods 2 – short rods 1 – handle rod 1 – T rod	Also locate hardware: 1 – rod coupling with 2 jam nuts 8 – heim ends with connecting nuts and bolts 2 – spacers
--	--

21. Slip spacer over threaded end of handle rod and insert rod into hole on cross bar near power column.
22. Slip spacer over threaded end of T-rod and insert end into hole located on opposite cross rail, taking care to run rod through rod guide located under ramp.
23. Thread jam nuts onto ends of handle rod and T-rod. Attach the handle rod to the T-rod using the rod coupling. Adjust coupling to take the slack out of the rods. The rods should remain free enough to move with no slack. Do not tighten coupler or lock nuts at this time.
24. Locate the two long rods and remove one end from each rod and slide off the eye bolt. Attach eye bolts to center of cross rails by threading ½ of the way in and tighten jam nut.
25. Attach short rod on the T side lock and to the bottom of the T and hand tighten. Slide long rod through the eye bolt and attach one end to the top

side of T. Attach the other end of the long rod to the lock on the other side. Repeat this process for the other end of the lift. The locking rods should be in perfect alignment since the lift is still sitting in the locked position. Tighten all jam nuts, making sure the linkage does not bind.

26. Go back to the coupler that attaches the T rod to the handle rod and tighten the jam nuts. Do not adjust coupler, only tighten the jam nuts.

Final Adjustments

27. Fill the tank with three gallons of R & O, ISO32 Hydraulic Oil (Available at any auto supply store).
28. Check over cables and make sure they are all in their pulleys. Press the up switch on the power unit and the fluid will start to pump into the cylinder. The lift will eventually rise after the cylinder fills up. Once the lift is raised of the locks, release the up switch and pull the lock lever to disengage the locks and lower the lift with the lowering lever on the power unit. Hold the lever after the lift reaches the very bottom until you hear all the air escape.
29. Raise the lift up to the point where the square blocks above the lock aligns with the second column lock, and stop. Look at each column lock to determine the highest point. Adjust the cable on the highest point column until three threads pass through the nylock nut. Now adjust the other three cables to match this height.
NOTE: There will be some initial stretching of the cables in the beginning. It will be necessary to readjust the cables a week after first use, then every six months thereafter. Run the lift up and down a few times to insure that the locks are engaging uniformly and that the safety release mechanisms are functioning properly. Readjust if necessary.
30. After the cables are installed and adjusted, unbolt the sheave covers (Item # 69), Figure # 2. Slide the sheave covers up the cable until you can access the cable sheave. Install the 8mm cable retention bolts into the threaded holes by the sheaves at the end of the crossbeams (Item # 101 and 102) Figure # 2. Assure they extend across the width of the sheaves and the bolt heads do not interfere with the sheaves. Install the 8mm lock nuts to the end of the bolts to lock them into position. Re-install sheave covers.

Caster Kit Installation

1. Install caster wheels to caster frames as shown.

NOTE: Hitch Pin and Hairpin Clip will be used to attach casters to lift in following steps. DO NOT install at this time.

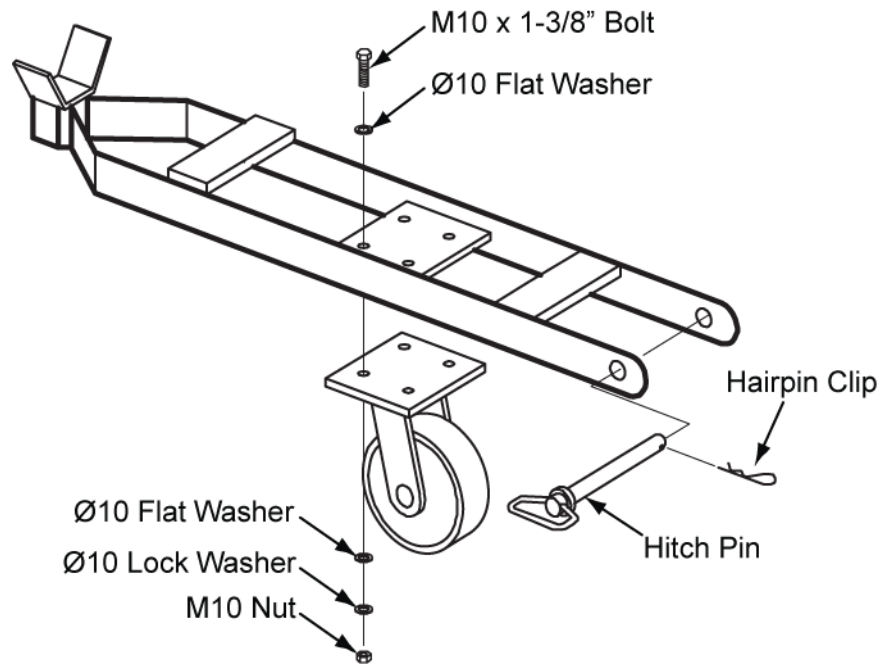

1. Raise lift 2' – 3' high.
2. Place caster assemblies under crossbeams as shown. Secure with Hitchpin and Hairpin Clip.
3. Lower lift and the columns will automatically raise off the floor.

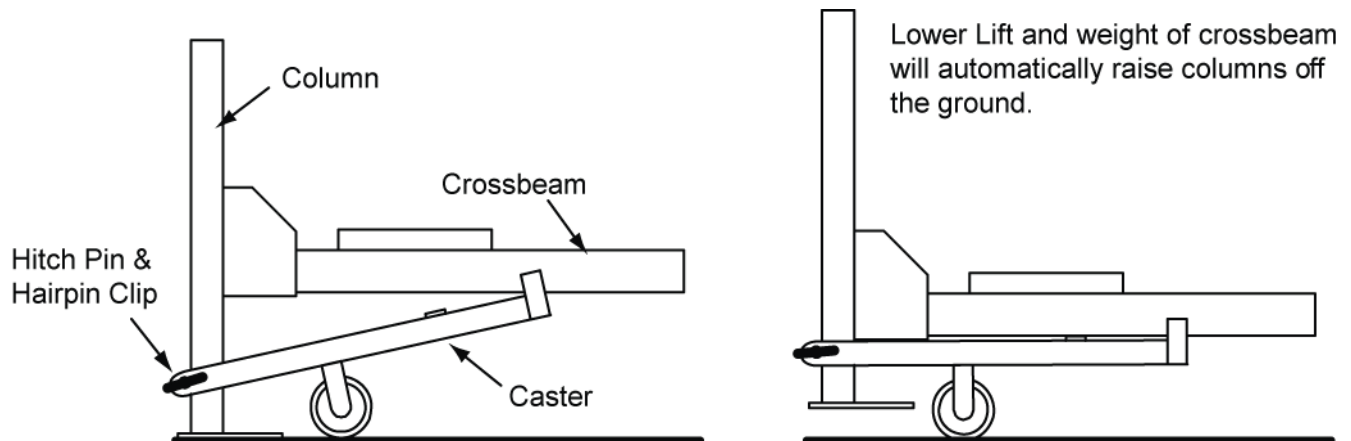

Foundation Requirements

Concrete shall have compression strength of at least 3,000 PSI and a minimum thickness of 4".

CAUTION!! DO NOT use on asphalt or similar unstable surfaces.

SPECIAL NOTE:

**This Lift does not require bolting to the floor
(BUT)**

**If you choose the option to anchor the Lift to the floor
please follow the detailed instructions and criteria below.**

Foundation And Anchoring Requirements

1. Concrete shall have compression strength of at least 3,000 PSI and a minimum thickness of 4" in order to achieve a minimum anchor embedment of 3 ¼".
NOTE: When using (¾" x 5 ½") long anchors; if the top of the anchor exceeds 2 ¼" above the floor grade, you DO NOT have enough embedment.
2. Maintain a 6" minimum distance from any slab edge or seam. Hole to hole spacing should be a minimum 6 ½" in any direction. Hole depth should be a minimum of 4".
3. Shim each column base as required until each column is plumb. If one column has to be elevated to match the plane of the other column, full size base shim plates should be used. Torque anchors to 110 ft-lbs. Shim thickness MUST NOT exceed ½" when using the 5 ½" long anchors with the lift. Adjust the column extensions plumb.
4. If anchors do not tighten to 110 ft-lbs. installation torque, replace the concrete under each column base with a 4' x 4' x 6" thick 3,000 PSI minimum concrete pad keyed under and flush with the top of existing floor. Allow concrete to cure before installing lifts and anchors (typically 2 to 3 weeks).

CAUTION!!

LUBRICATE ALL CABLE SHEAVES, BEARINGS, AND SHAFTS WITH GREASE PRIOR TO OPERATING THE LIFT. LUBRICATE ALL ON AN ANNUAL BASIS.

Motors and all electrical components are not sealed against the weather and moisture. Install this lift in a protected indoor location. Failure by the owner to provide the recommended shelter could result in unsatisfactory lift performance, property damage, or personal injury.

Lift Lockout/Tagout Procedure

Purpose

This procedure establishes the minimum requirements for the lockout of energy that could cause injury to personnel by the operation of lifts in need of repair or being serviced. All employees shall comply with this procedure.

Responsibility

The responsibility for assuring that this procedure is followed is binding upon all employees and service personnel from outside service companies (i.e., Authorized Installers, contactors, etc.). All employees shall be instructed in the safety significance of the lockout procedure by the facility owner/manager. Each new or transferred employee along with visiting outside service personnel shall be instructed by the owner/manager (or assigned designee) in the purpose and use of the lockout procedure.

Preparation

Employees authorized to perform lockout shall ensure that the appropriate energy isolating device (i.e., circuit breaker, fuse, disconnect, etc.) is identified for the lift being locked out. Other such devices for other equipment may be located in close proximity of the appropriate energy isolating device. If the identity of the device is in question, see the shop supervisor for resolution. Assure that proper authorization is received prior to performing the lockout procedure.

Sequence of Lockout Procedure

1. Notify all affected employees that a lockout is being performed and the reason for it.
2. Unload the subject lift. Shut it down and assure the disconnect switch is "OFF" if one is provided on the lift.

3. The authorized lockout person operates the main energy isolation device removing power to the subject lift.
 - a. If this is a lockable device, the authorized lockout person places the assigned padlock on the device to prevent its unintentional reactivation. An appropriate tag is applied stating the person's name, at least 3" x 6" in size, an easily noticeable color, and states not to operate device or remove tag.
 - b. If this device is a non-lockable circuit breaker or fuse, replace with a "dummy" device and tag it appropriately as mentioned above.
4. Attempt to operate lift to assure the lockout is working. Be sure to return any switches to the "OFF" position.
5. The equipment is now locked out and ready for the required maintenance or service.

Restoring Equipment to Service

1. Assure the work on the lift is complete and the area is clear of tools, vehicles, and personnel.
2. At this point, the authorized person can remove the lock (or dummy circuit breaker or fuse) and tag and activate the energy isolating device so that the lift may again be placed into operation.

Rules for Using Lockout Procedure

Use the Lockout Procedure whenever the lift is being repaired or serviced, waiting for repair when current operation could cause possible injury to personnel, or for any other situation when unintentional operation could injure personnel. No attempt shall be made to operate the lift when the energy isolating device is locked out.

Operating Conditions

Lift is not intended for outdoor use and has an operating ambient temperature range of 41°-104°F (5°-40°C).

Important Safety Instructions

When using your garage equipment, basic safety precautions should always be followed, including the following:

1. Read all instructions
2. Care must be taken as burns can occur from touching hot parts.
3. Do not operate equipment with a damaged cord or if the equipment has been dropped or damaged - until it has been examined by a qualified service person.
4. Do not let a cord hang over the edge of the table, bench, or counter or come in contact with hot manifolds or moving fan blades.
5. If an extension cord is necessary, a cord with a current rating equal to or more than that of the equipment should be used. Cords rated for less current than the equipment may overheat.
6. Always unplug equipment from electrical outlet when not in use. Never use the cord to pull the plug from the outlet. Grasp plug and pull to disconnect.
7. Let equipment cool completely before putting away. Loop cord loosely around equipment when storing.
8. To reduce the risk of fire, do not operate equipment in the vicinity of open containers of flammable liquids (gasoline).
9. Adequate ventilation should be provided when working on operating internal combustion engines.
10. Keep hair, loose clothing, fingers, and all parts of body away from moving parts.
11. To reduce the risk of electric shock, do not use on wet surfaces or expose to rain.
12. Use only as described in this manual. Use only manufacturer's recommended attachments.
13. **ALWAYS WEAR SAFETY GLASSES.** Everyday eyeglasses only have impact resistant lenses, they are not safety glasses.

Save These Instructions

Safety Procedures

- Never allow unauthorized persons to operate lift. Thoroughly train new employees in the use and care of lift.
- Caution - the power unit operates at high pressure.
- Remove passengers before raising vehicle.
- Prohibit unauthorized persons from being in shop area while lift is in use.
- Total lift capacity is 8,000 lbs. Do not exceed this capacity.
- Prior to lifting vehicle, walk around the lift and check for any objects that might interfere with the operation of lift and safety latches; tools, air hoses, shop equipment.
- When approaching the lift with a vehicle, make sure to center the vehicle between the columns. Slowly drive the vehicle up with someone outside the vehicle guiding the driver.
- Prior to lowering vehicle, walk around the lift and check for any objects that might interfere with the operation of lift and safety latches; tools, air hoses, shop equipment.
- Slowly drive the vehicle on and off of the lift. Have someone outside the vehicle guide the driver.

Caution - Watch Carefully!

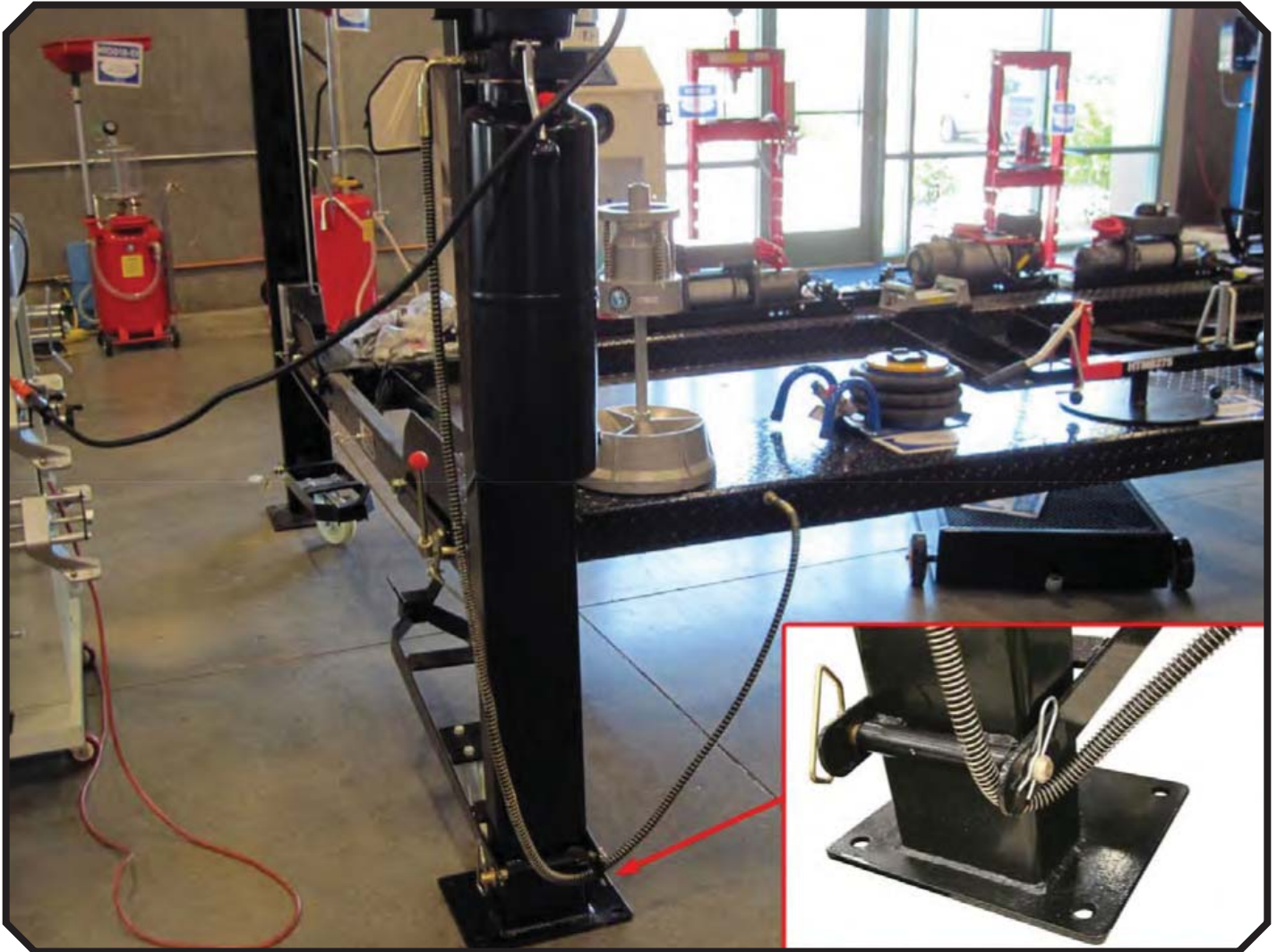

Do not allow the hydraulic hose to get caught on the caster support rod. When you raise the lift the hydraulic line may be pulled from the power unit or the cylinder resulting in a HUGE oil spill. This is not covered by warranty. Please pay attention.

Operation Instructions

NOTE: Always Chock Wheels And Set Parking Brake Before Lifting Vehicle!

Only authorized personnel are to operate lift.

- Properly maintain and inspect lift in accordance to owner' manual.
- Do not operate a lift that is damaged or in need of repair.
- Allow only authorized personnel in the lift bay.
- Stay clear of lift when raising or lowering (no riders).
- Keep hands and feet away from pinch points at all times.
- Never override the lift operating and safety controls.
- If a vehicle is suspected of falling, clear area immediately.
- Do not rock vehicle while positioned on lift.
- Always use safety jack stands when removing or installing heavy components.

Vehicle Loading:

- Position vehicle on lift runways by having another person guide you onto the runways. Check for proper weight distribution (center of gravity should be evenly distributed between columns).
- Set vehicle parking brake and chock tires to prevent vehicle movement.
- Use caution before lifting pickup trucks, suv's and other vehicles. The individual axle weight capacity should not exceed 1/2 of lift capacity.
- Make sure vehicle is neither front nor rear heavy.

Raising Lift:

- Push up switch to raise lift until platform runways clear floor.
- Stop and check for vehicle movement and vehicle weight distribution. If secure raise to desired height.
- Always lower the lift to the nearest lock position by pressing the lower lever to relieve the hydraulic pressure and let the latch set tight in a lock position.
- Never work under a lift that is not in the locked position.

Lowering Lift:

- Clear all obstacles from under lift and vehicle, and ensure only lift operator is in the lift area.
- Stay clear of lift and raise the lift off the safety locks.
- Pull safety latch releases and press the lower lever to begin descent.
- Ensure lift is fully lowered, and having another person guide you, carefully unload the lift by driving off of the lift runways.

CAUTION

PAY ATTENTION TO THE LOWERING SPEED OF ALL FOUR CORNERS. MAKE SURE THEY ARE MOVING DOWN AT THE SAME SPEED. STOP LOWERING THE LIFT BY RELEASING THE LOWERING LEVER ON THE POWER UNIT AND MOVING THE LOCK LEVER TO THE LOCK POSITION IF ANY CORNER STOPS MOVING OR IS SLOWER IN DESCENT. ALWAYS LOCK THE LIFT BEFORE GOING UNDER THE VEHICLE.

Preventive Maintenance Schedule

The periodic Preventive Maintenance Schedule given is the suggested minimum requirements and minimum intervals; accumulated hours or monthly period, which ever comes sooner.

Periodic maintenance is to be performed on a daily, weekly, and yearly basis as given in the following paragraphs. In the event you need replacement parts

WARNING!!

Occupational Safety and Health Administration (OSHA) and the American National Standards Institute (ANSI) requires users to inspect lifting equipment at the start of every shift. These and other periodic inspections are the responsibility of the user.

Failure to perform the daily pre-operational check can result in expensive property damage, lost production time, serious personal injury, and even death. The safety latch system must be checked and working properly before the lift is put to use.

Failure to heed this warning can result in death or serious injury, or damage to equipment. If you hear a noise not associated with normal lift operation,

or, if there is any indications of impending lift failure - CEASE OPERATION IMMEDIATELY! - Inspect, correct and/or replace parts as required.

Daily Pre-Operation Check (8-Hours)

- Check safety lock audibly and visually while in operation
- Check safety latches for free movement and full engagement with rack.
- Check hydraulic connections, and hoses for leakage.
- Check cables connections bends, cracks-and for loose fittings.
- Check for frayed cables in both raised and lowered position.
- Check snap rings at all rollers and sheaves.
- Check bolts, nuts, and screws and tighten if needed.
- Check wiring & switches for damage.
- Check floor for stress cracks near columns.
- Check Lubrications on cable sheaves and shafts.

Weekly Maintenance (every 40-Hours)

- **IF LIFT IS ANCHORED TO FLOOR** - Check anchor bolts torque to **110 ft-lbs** for the $\frac{3}{4}$ in. anchor bolts. Do not use an impact wrench to tighten anchor bolts.
- Check floor for stress cracks near columns
- Check hydraulic oil level.
- Check and tighten bolts, nuts, and screws.
- Check all cable sheaves/assembly for free movement or excessive wear on cable sheave shaft.

Yearly Maintenance

- Lubricate the cable sheave shaft by using grease gun at least once a year after the lift is in service.
- Check for excessive wear of cable. Replace them if necessary.
- Change the hydraulic fluid - good maintenance procedure makes it mandatory to keep hydraulic fluid clean. No hard fast rules can be established; - operating temperature, type of service, contamination levels, filtration, and chemical composition of fluid should be considered. If operating in dusty environment shorter interval may be required.

Special Maintenance Tasks

NOTE: The following items should only be performed by a trained maintenance expert:

- Replacement of hydraulic hoses.
- Replacement of cables and sheaves.
- Replacement or rebuilding air and hydraulic cylinders as required.
- Replacement or rebuilding pumps / motors as required.
- Checking of hydraulic cylinder rod and rod end (threads) for deformation or damage.

CAUTION

Relocating or changing components may cause problems. Each component in the system must be compatible; an undersized or restricted line will cause a drop in pressure. All valve, pump, and hose connections should be sealed and/or capped until just prior to use. Air hoses can be used to clean fittings and other components. However, the air supply must be filtered and dry to prevent contamination. Most important is cleanliness; Contamination is the most frequent cause of malfunction or failure of hydraulic equipment.

Troubleshooting

The common problems that may be encountered and their probable causes are covered in the following paragraphs:

PROBLEM	SOLUTION
Motor Does Not Operate	<p>Failure of the motor to operate is normally caused by one of the following:</p> <ol style="list-style-type: none"> 1. Breaker or fuse blown. 2. Faulty wiring connections; call electrician. 3. Defective up button; call electrician for service.
Motor Functions but Lift Will Not Rise	<p>If the motor is functioning, but the lift will not rise do the following in the order given:</p> <ol style="list-style-type: none"> 1. A piece of trash is under check valve. Push handle down and push the up button at the same time. Hold for 10-15 seconds. This should flush the system. 2. Check the clearance between the plunger valve of the lowering handle. There should be 1/16" clearance. 3. Remove the check valve cover and clean ball and seat. <p style="text-align: center;">WARNING!!</p> <p>Failure to properly relieve pressure in the following step can cause injury to personnel. This lift uses ISO Grade 32 or other good grade non-detergent hydraulic oil at a high hydraulic pressure. Be familiar with its toxicological properties, precautionary measures to take, and first aid measures as stated in the Safety Summary before performing any maintenance with the hydraulic system.</p> <ol style="list-style-type: none"> 4. Oil level too low. Oil level should be just under the vent cap port when the lift is down. Relieve all hydraulic pressure and add oil as required.

Oil Blows out Breather of Power Unit	<p>If oil blows out of the breather of the power unit, take the following actions:</p> <ol style="list-style-type: none"> 1. Oil reservoir overfilled. Relieve all pressure and siphon out hydraulic fluid until at a proper level 2. Lift lowered too quickly while under a heavy load. Lower the lift slowly under heavy loads.
Motor Hums and Will Not Run	<p>If the motor hums but fails to run, take the following actions:</p> <ol style="list-style-type: none"> 1. Lift overloaded. Remove excessive weight from lift <p style="text-align: center;">WARNING!!</p> <p>The voltages used in the lift can cause death or injury to personnel. In the following steps, make sure that a qualified electrician is used to perform maintenance</p> <ol style="list-style-type: none"> 2. Faulty wiring Call electrician 3. Bad capacitor Call electrician 4. Low voltage Call electrician
Lift Jerks Going Up and Down	<ol style="list-style-type: none"> 1. If the lift jerks while going up and down, it is usually a sign of air in the hydraulic system. Raise lift all the way to top and return to floor. Repeat 4-6 times. Do not let this overheat power unit.
Oil Leaks	<p>Oil leak causes at the power unit and cylinders are normally caused by the following:</p> <ol style="list-style-type: none"> 1. Power unit: if the power unit leaks hydraulic oil around the tank-mounting flange check the oil level in the tank. The level should be two inches below the flange of the tank. A screwdriver can be used as a "dipstick". 2. Cylinder - Piston Rod: the rod seal of the cylinder is out. Rebuild or replace the cylinder. 3. Cylinder - Vent: the piston seal of the cylinder is out. Rebuild or replace the cylinder.

<p>Lift makes excessive noise / vibrates</p>	<p>Excessive noise from the lift is normally caused by the following:</p> <ol style="list-style-type: none"><li data-bbox="389 199 1521 283">1. Cross beam ends are rubbing the columns. Readjustment needed.<li data-bbox="389 304 1521 472">2. Cylinder too tight, load lift half capacity and cycle up and down a few times to break in. Lift cylinder should quiet down with use. If not contact your Distributor to purchase an Oil Additive.<li data-bbox="389 493 1521 577">3. May have excessive wear on cable sheaves or shafts. Replace them.
--	--

Cable Inspection Guide

Maximum Allowable Cable Necking

Nom. Cable Diameters Max. Reduction in Diameter	
Up to 5/16"	1/64"
3/8" to 1/2"	1/32"
9/16" to 3/4"	3/64"
7/8" to 1-1/8"	1/16"
1-1/4" to 1-1/2"	3/32"

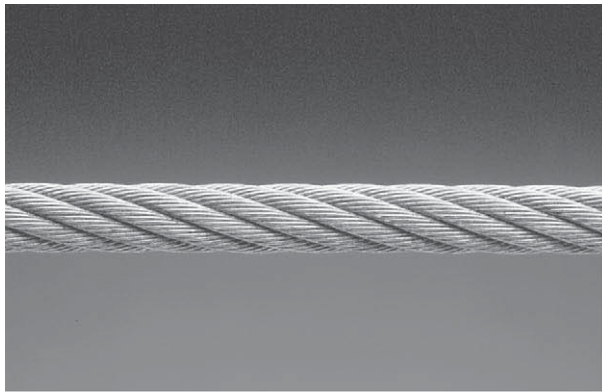

Typical Good Cable

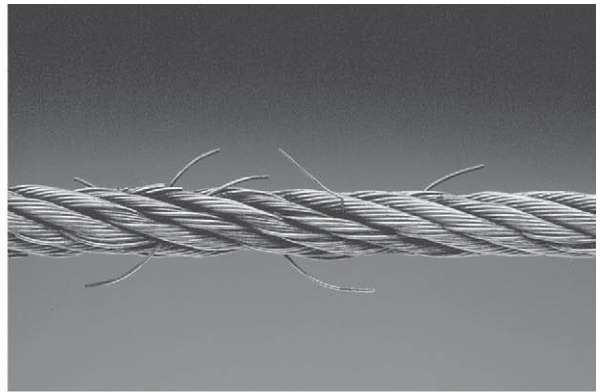

Cable With Broken Wires

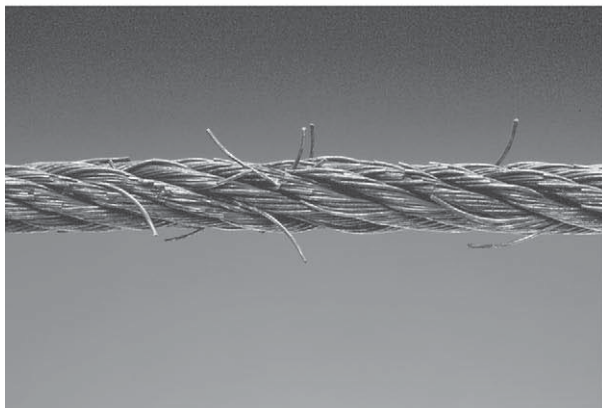

Cable With Severe Corrosion



Cable With Necking

Daily Inspection & Maintenance

1. Cleanliness: Cables, Columns, Runways and other lift parts should be kept free of corrosive agents, solvents, and road salts. If such agents are spilled or splashed on any lift component, immediately rinse thoroughly with water and wipe down with a clean rag. Spray wire rope cables as required with Penetrating Oil and wipe down. Failure to keep lift free of corrosive agents and solvents will lead to reduced component service life, cable failure, etc., which could result in property damage and/or personal injury.
2. Fasteners: Check all the attaching bolts and nuts for tightness.
3. Cables: Check wire rope cables for wear or damage. Any cable with broken wires, severe corrosion, excessive stretch, deformed strands, variations in diameter (necking), or any change from its normal appearance, must be replaced. If any cable is found to be in need of replacement, the entire cable set must be replaced immediately. Refer to figures below.
4. Sheaves: Check sheaves (pulleys) for wear or damage, i.e. wobble (tilt), cracks, loose on pin, or excessive noise during operation.
5. Sheave Pins: Check for loose or missing sheave (pulley) pins.
6. Locking Latches and Slack Cable Devices: Watch locking latches and slack cable devices during lift operation to ensure that latches work properly and line up with slots in latch plate located in columns.

Monthly Inspection & Maintenance

1. Cables
 - a. Clean wire rope cables with lift in both lowered and raised position by spraying with Penetrating Oil and wiping the cable down.
 - b. Adjust cables using procedures on following pages.
2. Slack Cable Device: Inspect slack cable devices using procedure on page 5.
3. Column Anchor Bolts: Check column anchor bolts for tightness. Re-torque anchors bolts to 110 ft-lbs. If anchors do not tighten to the required installation torque, replace concrete under each column base per installation instructions. Let concrete cure before installing lifts and anchors.
4. Columns: Look for corrosion, giving special attention to the area at the base of the column. Check severely corroded areas by pecking with an awl or welder's chipping hammer. If column is corroded through at any point it must be replaced immediately. If not corroded through, remove old paint and rust scale, then coat with a high quality corrosion resistant paint.

NOTE: A thorough inspection of the lifting system must be performed quarterly by qualified lift service personnel; more frequently (monthly) under extreme service conditions such as outside installations or high usage (10 or more cycles per day, etc.).

Quarterly Inspection & Maintenance

Cables

1. Inspect cables in both lowered and raised position. The cables may also be viewed through various inspection holes and openings in yokes and runways. Check all the following:
 - a. That cables have no broken wires visible, reference Daily Inspection & Maintenance.
 - b. That cables are free of severe corrosion and pitting, reference Daily Inspection & Maintenance. A light surface corrosion on exposed outer wires is normal. Penetrating Oil should be applied during monthly periodic inspection.
 - c. That there are no areas on the cable that have a greatly reduced diameter or "necking", reference Daily Inspection & Maintenance. When any cable is found with excessive necking, all cables must be replaced immediately.
 - d. That cables do not have excessive stretch. It is normal for new cable to require adjustment during "break-in", after which small periodic adjustments may be required. However, if a cable that has been in service for 6 months should suddenly require frequent adjustments or has used all the cable adjustment available, all cables must be replaced immediately.
 - e. If any cable is found to be in need of replacement, the entire cable set must be replaced immediately.
 - f. Cables are expendable items and should be replaced as a set every 20,000 cycles (estimated) or every 6 years, unless earlier replacement is indicated during inspection.

Sheaves and Pins

1. Inspect sheaves and pins in yokes and runways. Sheaves are expendable items. Sheaves and pins should be replaced when worn. Use of sheaves and pins with excessive wear will lead to reduced service life of cables.
2. Inspect sheaves (pulleys) in yoke ends with lift in lowered position or resting on the locking latches.
 - a. Hold lowering handle down and pull on cable in column to create slack in cables.
 - b. Check for excessive side to side wobble. Grasp rim of sheave and attempt to wobble (tilt) side to side. If sheaves wobble (tilt) more than 3/16" (4.8 mm)

side to side or move up and down on shaft more than 1/32" (0.8 mm), the sheave and pin (shaft) should be replaced, refer figures below.

- c. Check sheaves and replace if cracks are found.
 - d. Check for ease of rotation. If sheaves do not turn freely, the sheave and sheave pin should be removed, inspected, lubricated, and reinstalled or replaced.
3. Fully raise lift. Inspect sheaves (pulleys) in runway ends with lift in raised position.
- a. Visually inspect alignment of sheaves, see figure below. Misalignment of sheave(s) indicates excessive wear; the sheave(s) and sheave pin should be removed and inspected. Replace as required.
 - b. Hold lowering handle down to lower lift onto latches. Pull on cables under runway to create cable slack.
 - c. Check for excessive side to side wobble. Grasp rim of sheave and attempt to wobble (tilt) side to side, refer to figures below. If sheaves wobble (tilt) more than 1/16" (1.6 mm) side to side, or move in and out more than 1/32" (0.8 mm), the sheave and sheave pin (shaft) should be replaced, refer to figures below.

Hydraulic Cylinder

1. Inspect the hydraulic cylinder mounting to the runway. Inspect cylinder and hydraulic hoses for leaks. Repair or replace as required.
 - a. Check and tighten the hydraulic cylinder rod nuts holding the cable pull bar.

TRACKS for Rolling Jack and Oil Drain Pan

1. Inspect rolling jack/oil drain pan tracks for cleanliness, corrosion, excessive wear or damage.
2. Clean dirty tracks.
3. Worn or damaged tracks must be repaired immediately. Failure to do so will lead to reduced service life which could result in property damage and/or personal injury.

Latch Inspection and Adjustment

1. Check locking latches for proper operation. Inspect for worn or missing parts. Replace worn or damaged parts and adjust as required.
2. Latches - Check latch operation on all four corners.
3. Latch and Latch Bar Line-Up - Observe locking latches during lift operation to ensure that all latches line up with slots in latch bar located in all four columns. If not, relocate and/or re-shim columns.
 - a. Check slack cable devices for proper operation. Inspect for worn or missing parts. Replace worn or damaged parts as required.

- b. Observe both locking latches and slack cable devices during lift operation to ensure that all latches line up with slots in latch bar located in all four columns.

Cable Adjustment

1. Initial Adjustment

- a. Adjust cable with lift fully lowered. Loosen jam nut and tighten nut on cable stud on top of column until yoke end is raised 1/4" (6.4 mm) and back off nut one turn. Retighten jam nut. Repeat for all four cables.

2. Final Adjustment

- a. Load a typical vehicle on lift.
- b. Raise lift as high as it will travel (full height). You should hear the locking latches click through all latch slots simultaneously.
- c. Lower lift onto top latch position.
- d. Check clearance:
 - i. Starting with the right front column, use a straight edge to mark the position of the yoke bottom on the column.
 - ii. Raise lift to full height again. Mark second position. If gap between two marks is less than 2", adjust locking latch bar to reach clearance of 2". Repeat for the other three columns.
 - iii. Adjust locking latch bar adjusting nut so that the bottom of the topmost latch bar slot is at least 2" below locking latch. After adjustment, tighten jam nut underneath column top plate.
 - iv. If entire 2" clearance cannot be attained by adjusting the locking latch bar, adjust the cable. Turn cable adjusting nut to raise the locking latch 2" above bottom of latch bar slot. Tighten cable jam nut.
- v. Lower lift and remove vehicle.
- vi. Raise the lift to full height. LISTEN and WATCH as the first locking latch clicks into place. Synchronize the other three columns with this column by adjusting their cables so all four latches click at same time. Tighten jam nuts. When making changes to adjustment nuts on cable end or latch bar stud, always leave at least two threads showing between nut and stud end. Latches may not click in at the same time when vehicle is being raised. They should be close. Be sure all four corners have passed the locking latch bar slot before lowering lift on locking latches

Illustrated Parts Breakdown

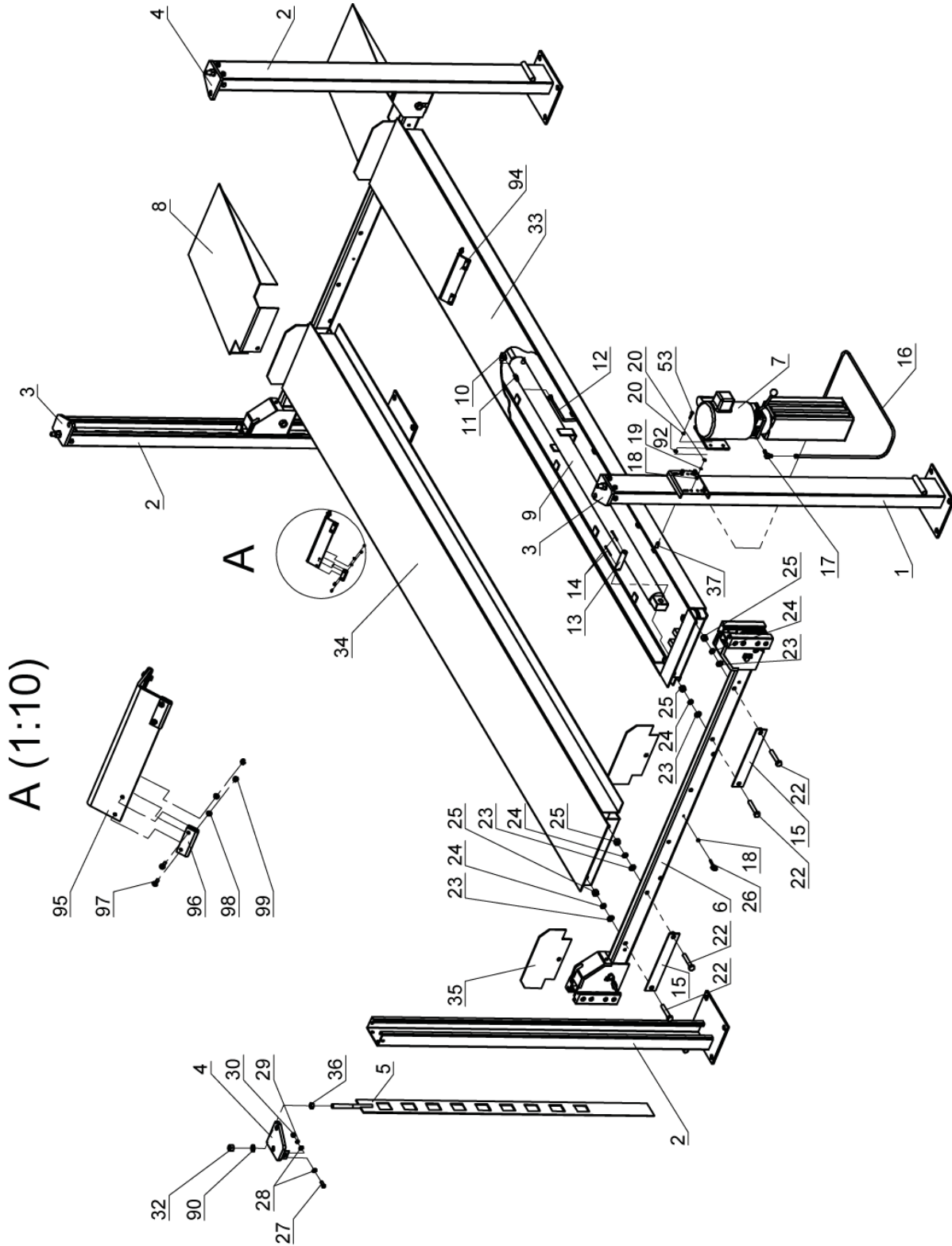

GENERAL ILLUSTRATED PARTS LIST – FIGURE #1

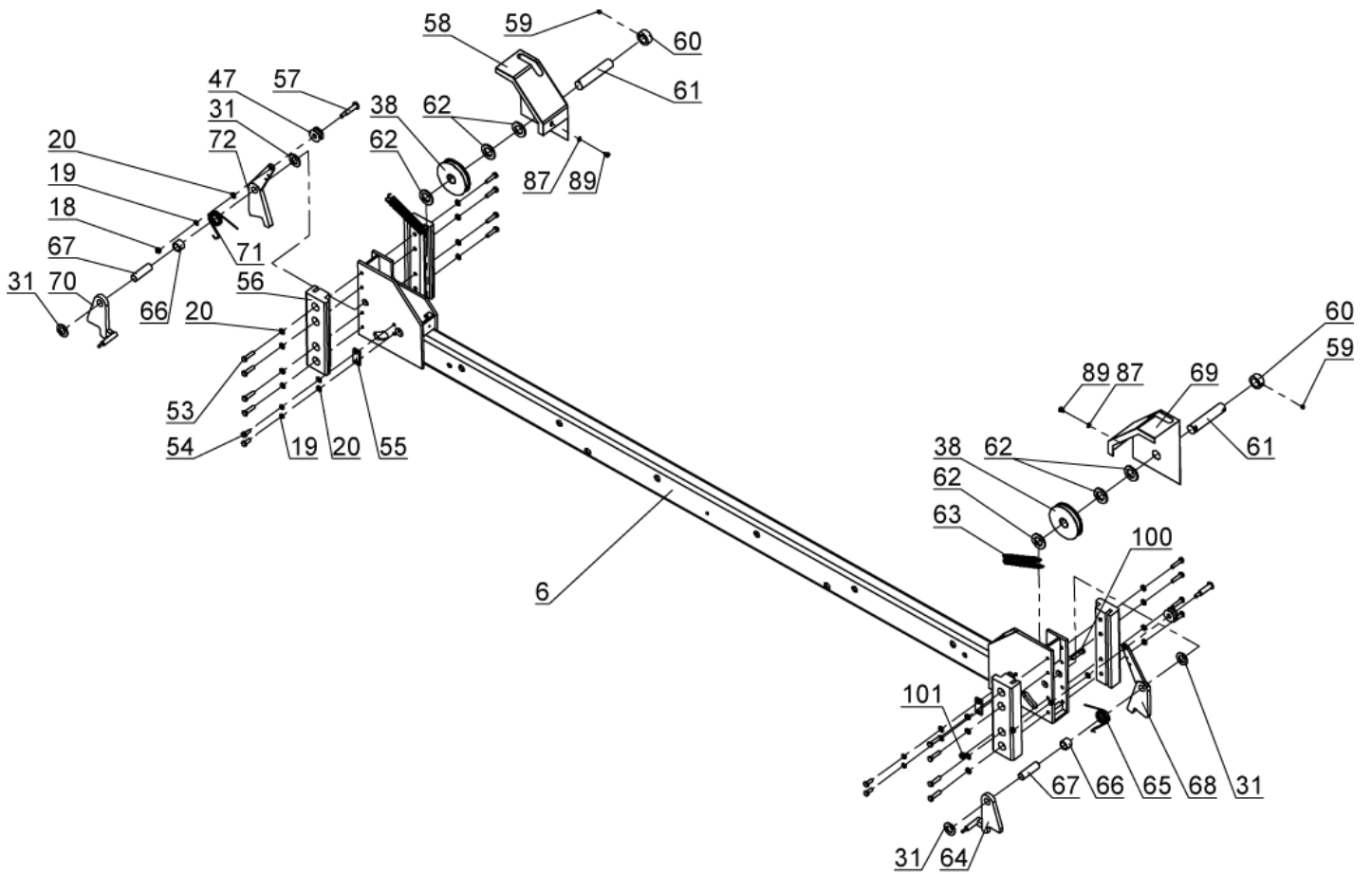

CROSSBEAM ASSEMBLY – FIGURE # 2

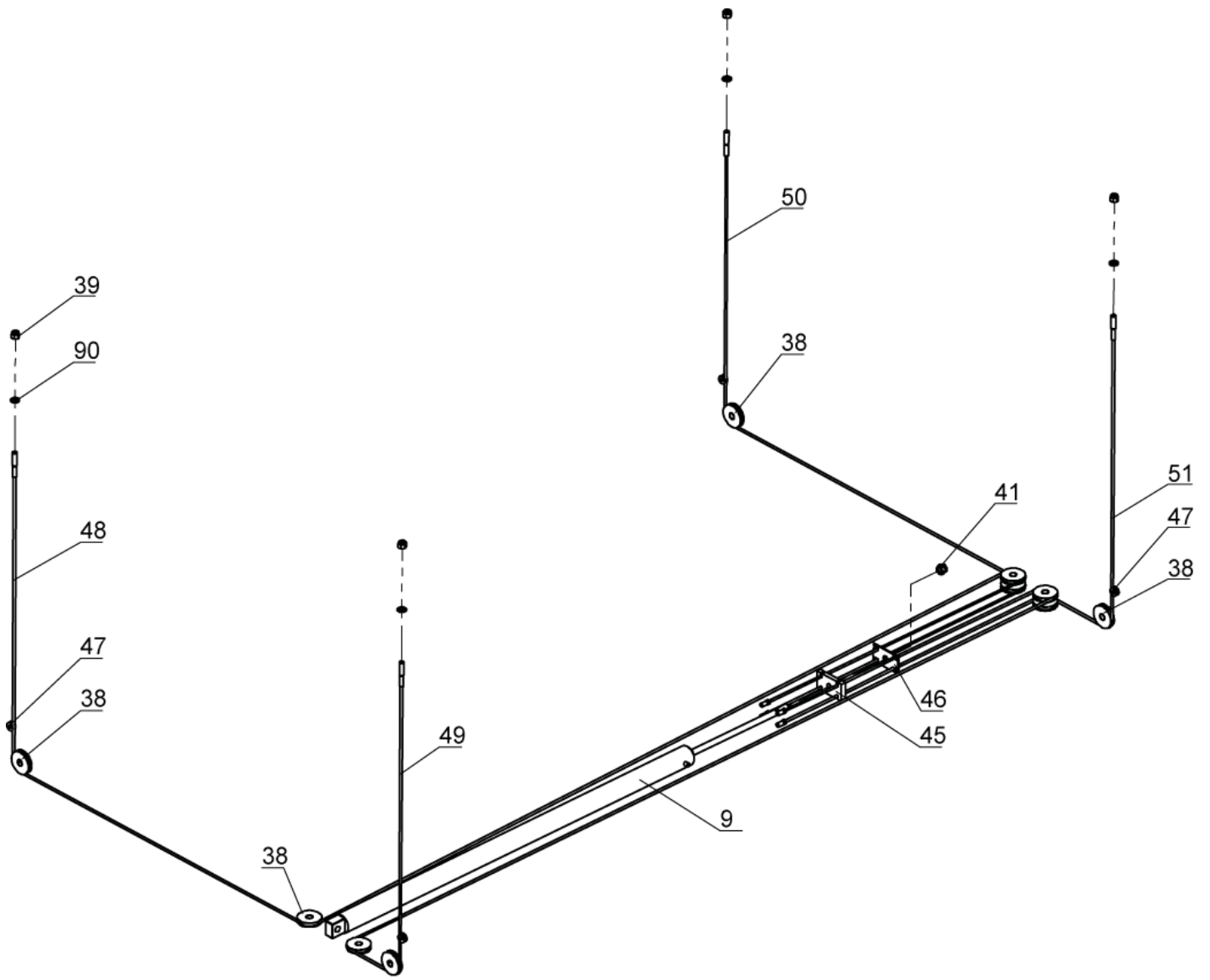

CABLE COMPONENTS & ROUTING – FIGURE # 3

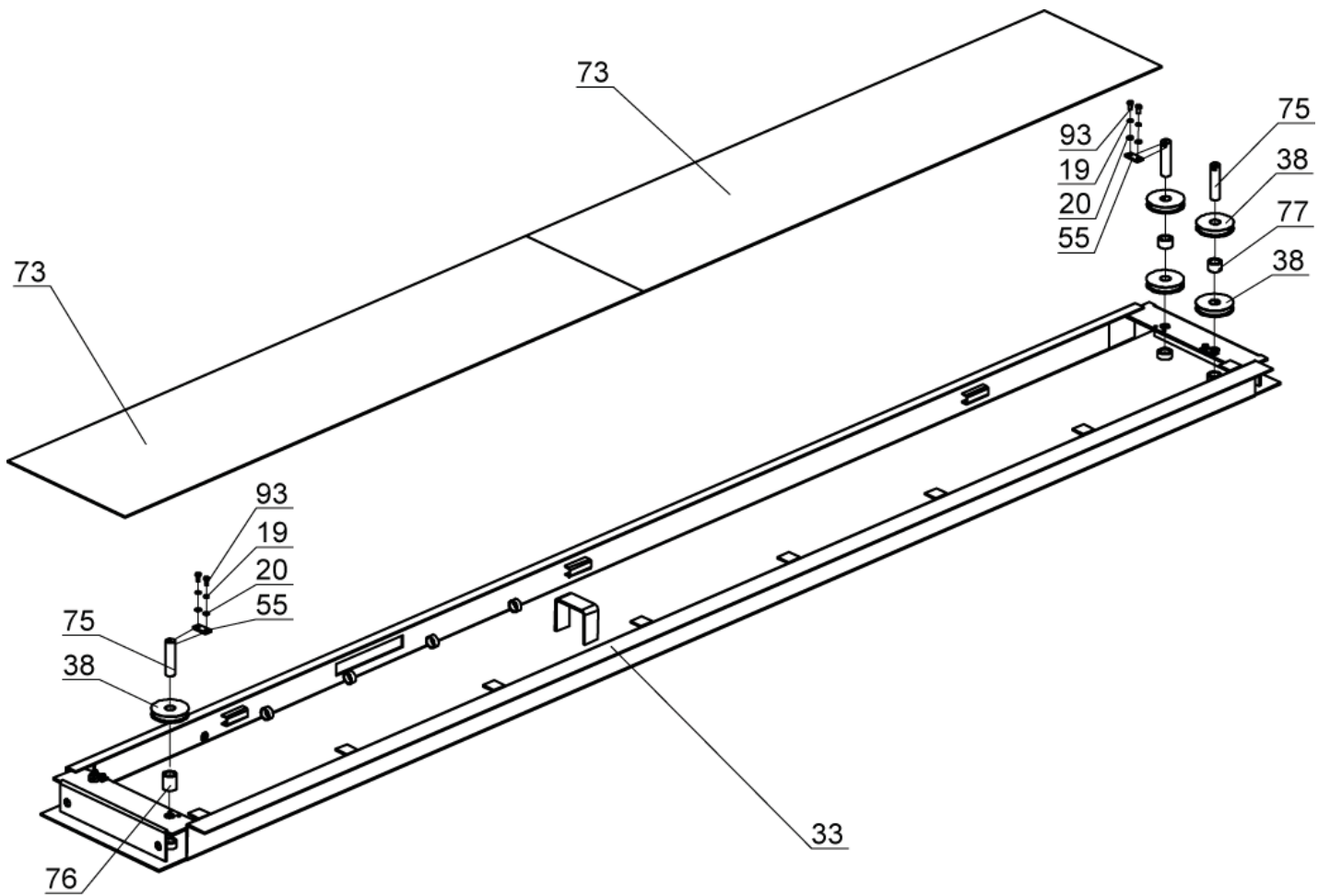

RUNWAY AND SHEAVE COMPONENTS - FIGURE # 4

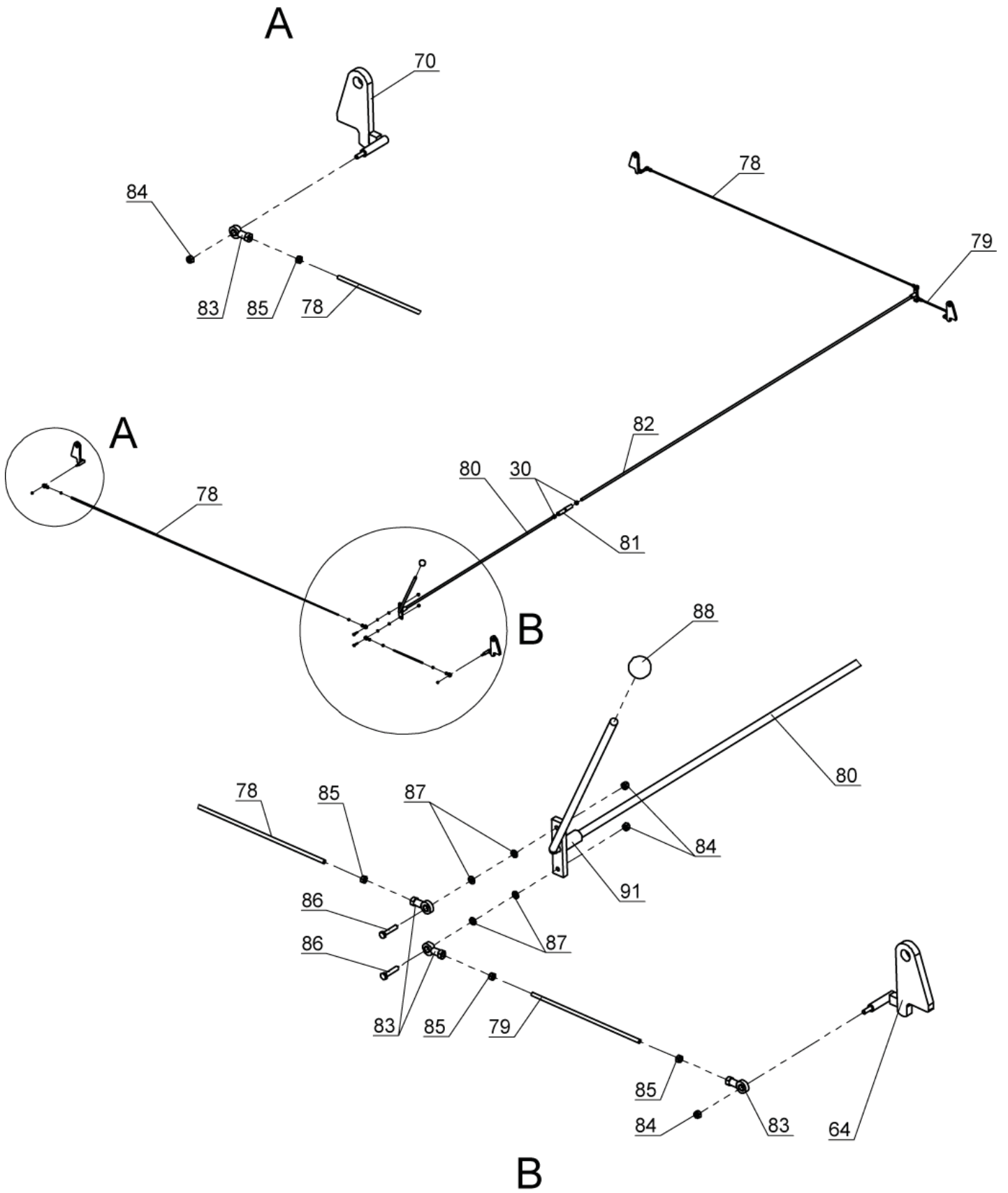

SAFETY LATCH & LINKAGE COMPONENTS – FIGURE # 5

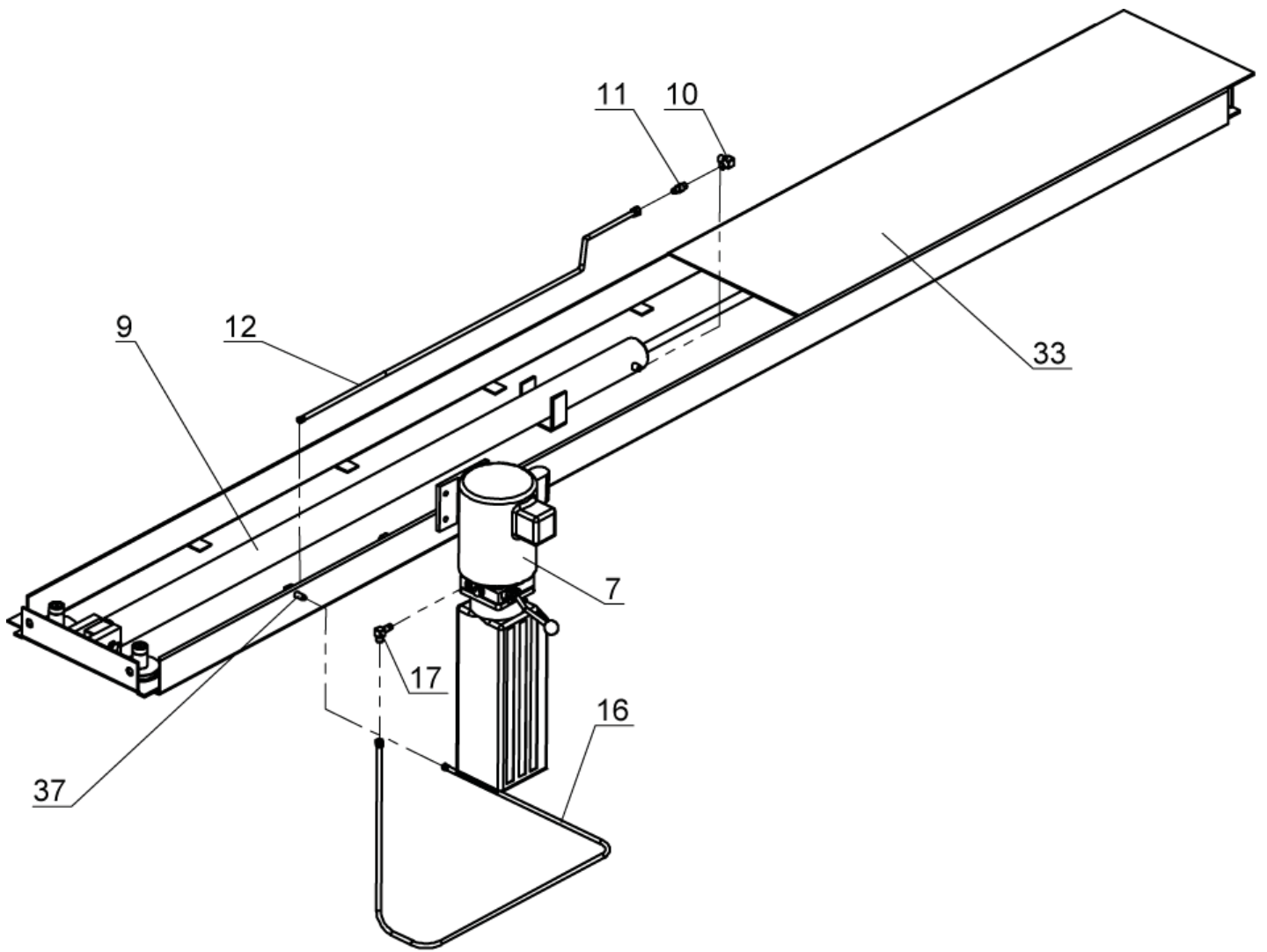

HYDRAULIC & CYLINDER COMPONENTS - FIGURE # 6

GP8000 Parts List

Items	Drawing #	Description	QTY
1	PP8S-1000	Column Weldment A	1
2	PP8S-1100	Column Weldment B	3
3	DP8-1200	Column Top Caps	2
4	DP8-1200DC	Column Top Caps	2
5	PP8S-1210	Latchbar Weldment	4
6	DP8-2100	Crossbeam Weldment	2
7	P/U	Power Unit	1
8	DP8-5000	Ramp Weldment	2
9	YG02-9100G	Hydraulic Cylinder	1
10	PP7-9802-2	Pipe Fitting	1
11	PP7-9200	Throttle	1
12	1WB-04	Hydraulic Hose	1
13	H4D-5005	Hydraulic Cylinder Pin	1
14	B52-5×60	Cotter Pin Ø 5×60	2
15	H4D-5000	Link Frame	4
16	1WB-05	Hydraulic Hose	1
17		90 Degree Fitting	1
18	B30-8	Nut M8	10
19	B40-8	Lock Washer Ø 8	24
20	B41-8	Flat WasherØ 8	60
22	B10-18×100	Hex Head Bolt M18 × 100	8
23	B41-18	Flat WasherØ 18	8
24	B40-18	Lock Washer Ø 18	8
25	B30-18	Nut M18	8
26	H4D-7001-07	Bolts M8×50	2
27	B10-12×30	Hex Head Bolt M12×30.	16
28	B41-12	Flat WasherØ 12	32
29	B40-12	Lock Washer Ø 12	16
30	B30-12	Nut M12	18
31	DP8-2013	Flat WasherØ 20	8
32	B30-20	Nut M20	4
33	PP8S-3100	Runway Weldment ,Driving Side	1
34	DP8-3200	Runway Weldment ,Slave Side	1

35	H4D-5001	Car Stop Plates	4
36	NH4D-3303	Nut	4
37	H4D-Y003	90 Degree Fitting	1
38	DP8-2012	Cable Pulley	10
39	B33-3/4"-16	Nylon Lock Nut 3/4"-16	4
41	B33-24×2	Nylon Lock Nut M24×2	1
45	H4D-5003	Cable Lock PlateA	1
46	H4D-5004	Cable Lock PlateB	1
47	DP8-2004	Small Cable Pulley	4
48	PP7-2004	Cable	1
49	PP7-2003	Cable	1
50	PP7-2002	Cable	1
51	PP7-2001	Cable	1
53	B10-8×35	Hex Head Bolt M8×35	36
54	B10-8×20	Hex Head Bolt M8×20	8
55	NH4D-2005	Lock Plate	8
56	DP8-2003	Slider	8
57	DP8-2009	Shaft	4
58	DP8-2001	Pulley Cover	2
59	B22-8×10	Set Screw M8×10	4
60	DP8-2007	Bushings	4
61	DP8-2006	Cable Pulley Pin	4
62	DP8-2014	Flat WasherØ 24C Level	12
63	NH4D-1011	Spring	8
64	DP8-2011DC	Work Lock	2
65	NH4D-1004	Spring	2
66	DP8-2008	Spacer	4
67	DP8-2005	Lock Shaft	4
68	DP8-2010DC	Safety Lock	2
69	DP8-2002	Pulley Cover	2
70	DP8-2011	Work Lock	2
71	NH4D-1004DC	Spring	2
72	DP8-2010	Safety Lock	2
73	H4D-5007	Plastic Plate	2
75	PP7-3001	Cable Pulley Shaft	4
76	PP7-3003	Spacer	2
77	PP7-3002	Spacer	2
78	DP8-4301	Long Rod	2
79	DP8-4401	Short Rod	2

80	DP8-4210	Joy Stick B	1
81	H4D-7000-03	Coupler	1
82	DP8-4110	Joy Stick A	1
83	B72-6	Bearing M6	8
84	B33-6	Nylon Lock Nut M6	8
85	B30-6	Nut M6	8
86	B10-6×30	Hex Head Bolt M6×30	4
87	B41-6	Flat WasherØ 6	12
88	B84-35	Plastic Knob For Handle Ø35×M10	1
89	B23-6×10	Discal Head Screw M6×10	4
90	B41-20	Flat WasherØ 20	8
91	H4D-7000-05	Steel Spacer	2
92	30400-1999	Washer	4
93	B10-8×16	Hex Head Bolt M8×16	8
94	H4P-R3100	Wheel Chock	2
95	H4P-R3101	Angle Iron	2
96	H4P-R3102	Rubber	8
97	B23-5×16	Discal Head Screw M5×16	8
98	B41-5	Flat WasherØ 5	8
99	B30-5	Nut M5	8
100	B10-8×40	Hex Head Bolt M8×40	4
101	B33-8	Nylon Lock Nut M8	4

Accessories for Four Post 8000 lb Lift

	PP8S-2000CK	Caster Kit - Assembly	4
1	PP8S-2000	Caster Kit - Frame Weldment	4
2	B80-6×2	Caster Kit - Caster Wheel Assembly 6"×2"	4
3	PP8S-2100	Caster Kit - Hitch Pin	4
4	H4D-5006-03	Caster Kit - Hairpin Clip	4
5	B30-10	Hex Nut - M10	16
6	B40-10	Lock Washer Ø10	16
7	B41-10	Flat Washer -Ø10	32
8	B10-10×35	Hex Bolt - M10×35	16
	DP7PNBKD-DT	Drip Tray	3
	H4D-6000	Jack Tray / Tool Box	1

Warranty



This item is warranted for two (2) years on structural components and one (1) year on air or electric hydraulic power units, pneumatic power units, cylinders and major components from date of invoice. Wear items are covered by a 90 day warranty.

This LIMITED warranty policy does **not include a labor** warranty.

NOTE: ALL WARRANTY CLAIMS MUST BE PRE-APPROVED BY THE MANUFACTURER TO BE VALID.

The Manufacturer shall repair or replace at their option for this period those parts returned to the factory freight prepaid, which prove after inspection to be defective. This warranty will not apply unless the product is installed, used and maintained in accordance with the Manufacturers installation, operation and maintenance instructions.

This warranty applies to the ORIGINAL purchaser only, and is non-transferable. The warranty covers the products to be free of defects in material and workmanship but, does not cover normal maintenance or adjustments, damage or malfunction caused by: improper handling, installation, abuse, misuse, negligence, carelessness of operation or normal wear and tear. In addition, this warranty does not cover equipment when repairs or alterations have been made or attempted to the Manufacturer's products.

THIS WARRANTY IS EXCLUSIVE AND IS LIEU OF ALL OTHER WARRANTIES EXPRESSED OR IMPLIED INCLUDING ANY IMPLIED WARRANTY OR MERCHANTABILITY OR ANY IMPLIED WARRANTY OF FITNESS FROM A PARTICULAR PURPOSE, AND ALL SUCH IMPLIED WARRANTIES ARE EXPRESSLY EXCLUDED.

THE REMEDIES DESCRIBED ARE EXCLUSIVE AND IN NO EVENT SHALL THE MANUFACTURER, NOR ANY SALES AGENT OR OTHER COMPANY AFFILIATED WITH IT OR THEM, BE LIABLE FOR SPECIAL CONSEQUENTIAL OR INCIDENTAL DAMAGES FOR THE BREACH OF OR DELAY IN PERFORMANCE OF THIS WARRANTY. THIS INCLUDES, BUT IS NOT LIMITED TO, LOSS OF PROFIT, RENTAL OR SUBSTITUTE EQUIPMENT OR OTHER COMMERCIAL LOSS.

PRICES: Prices and specifications are subject to change without notice. All orders will be invoiced at prices prevailing at time of shipment. Prices do not include any local, state or federal taxes.

RETURNS: Products may not be returned without prior written approval from the Manufacturer.

DUE TO THE COMPETITIVENESS OF THE SELLING PRICE OF THESE LIFTS, THIS WARRANTY POLICY WILL BE STRICTLY ADMINISTERED AND ADHERED TO.